



Pariposer Advantages

- Pariposer material has the following advantages in any interposer application.
 - A thin high-performance interposing fabric with bandwidth greater than 50 GHz.
 - Material is electrically near-transparent.
 - A contact region that conforms to the geometry of the application.
 - Material reconfigures for each application.
 - A contact region that matches the performance capability of the underlying design.
 - Advanced contact and transition designs can take advantage of the extraordinary performance of the material.



GigaCon™ Test Vehicle



- Board-to-board or Board-to-flex-to-board.
 - Common Low-cost materials
 - FR-4 (4-layer, 0.062” thick, Er = 4.2, TanDelta = 0.025)
 - Polyimide Flex (2-layer, Er = 3.1, TanDelta = 0.014)
 - SMA instrumentation connectors (> 30 GHz bandwidth)
 - Each PCB contains:
 - SMA
 - 3.3” FR-4 trace
 - GigaCon™ optimized contact area.
 - Mating flex contains:
 - Via in pad optimized contact area.
 - Pariposer material used as the contact interposer.



- Potential GigaCon contact transition structures were modeled with CST Microwave Studio, Finite Integration Technique full wave time domain field solver.
 - Two approaches taken:
 - Ideal contacts.
 - Approximate multiple cylindrical contacts.
 - Modeled section included:
 - Two 0.062” thickness FR-4 printed circuit boards.
 - Contact Pads and 0.062” thru vias.
 - Entry and exit microstrip traces.
 - Pariposer modeling.
 - Transitions were simulated and their structures optimized for minimum return loss.

Ideal Modeling

- Contact surface was modeled as a complete cylindrical metal surface with no additional interstitial conductive material.

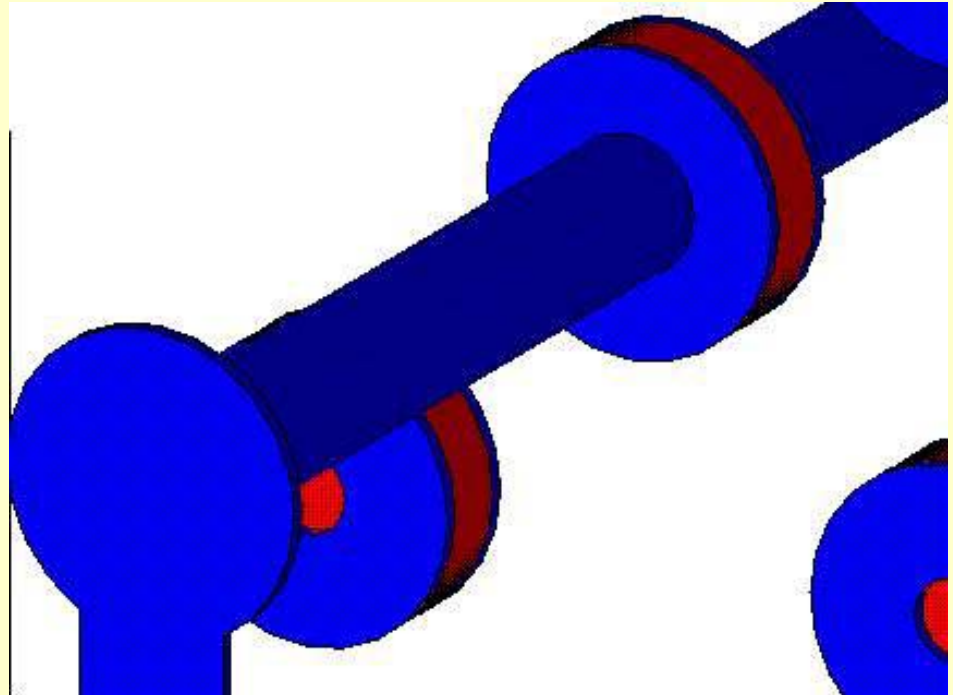

Approximate Modeling

- Contact surface was modeled with multiple cylindrical contacts approximating general Ballwire size and spacing.

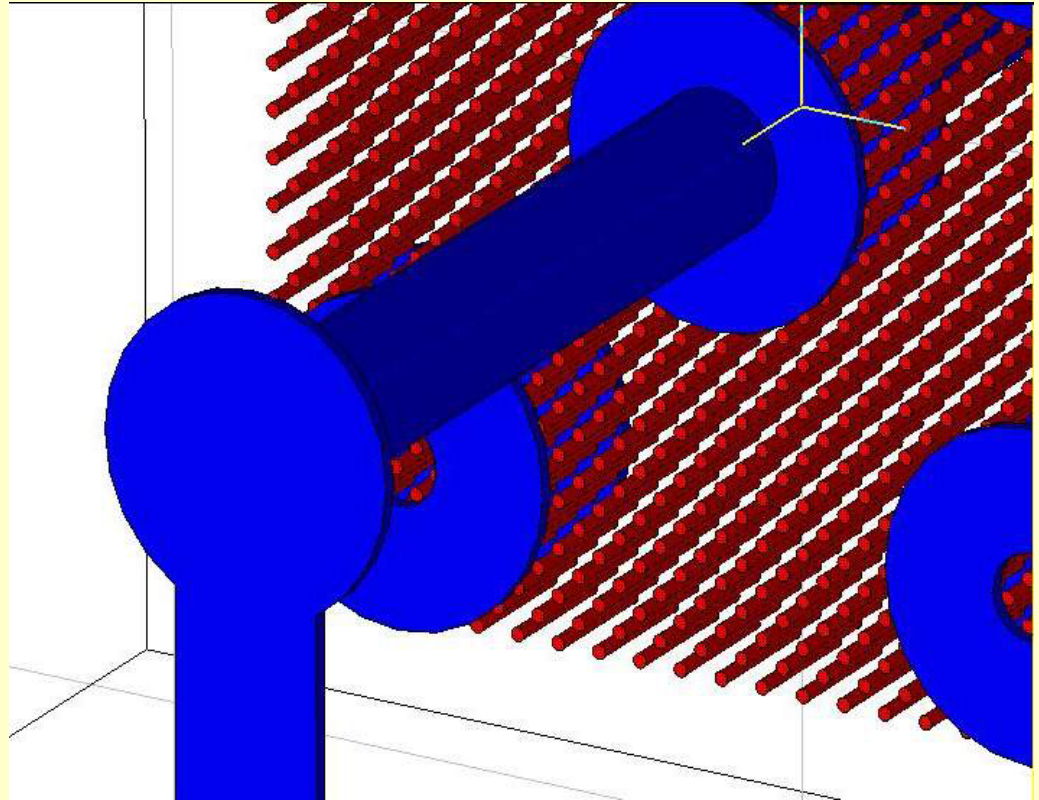

GigaCon Insertion Loss

- Insertion loss is dependent upon Pariposer thickness and modeling method.
- In all cases, sufficient bandwidth exists out beyond 20 GHz for 10 mil thickness, sufficient for 40 Gbps NRZ data transmission, and beyond 30 GHz for 5 mil thick material.

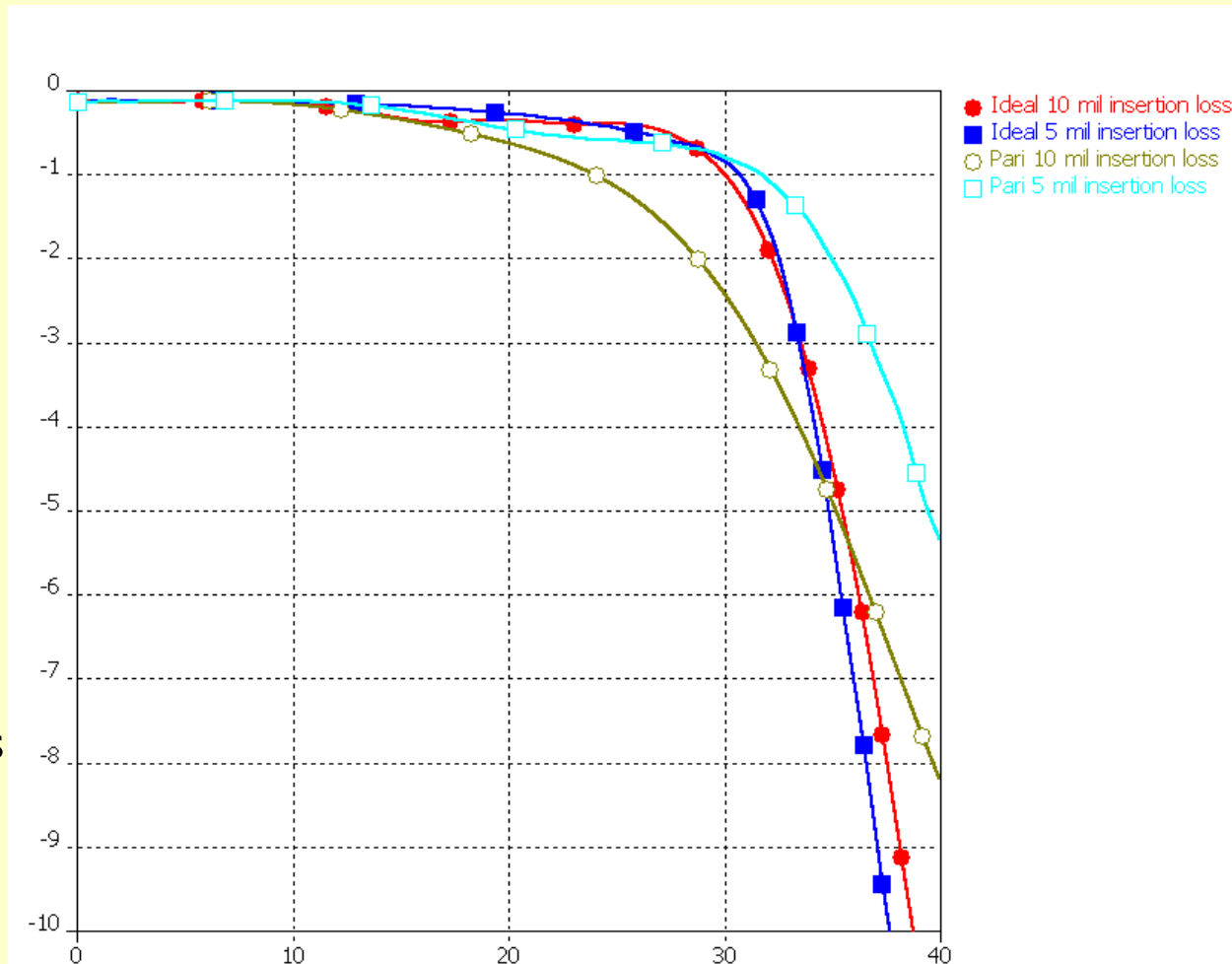

GigaCon Return Loss

- Return loss in all cases is below -10 dB out to 20 GHz.
- Return loss for 5 mil thick material is below -12 dB out to 30 GHz
- Additional interstitial metal causes a shift in return loss peaking, indicative of a decrease in effective ϵ_r , due to reduction of dielectric volume.

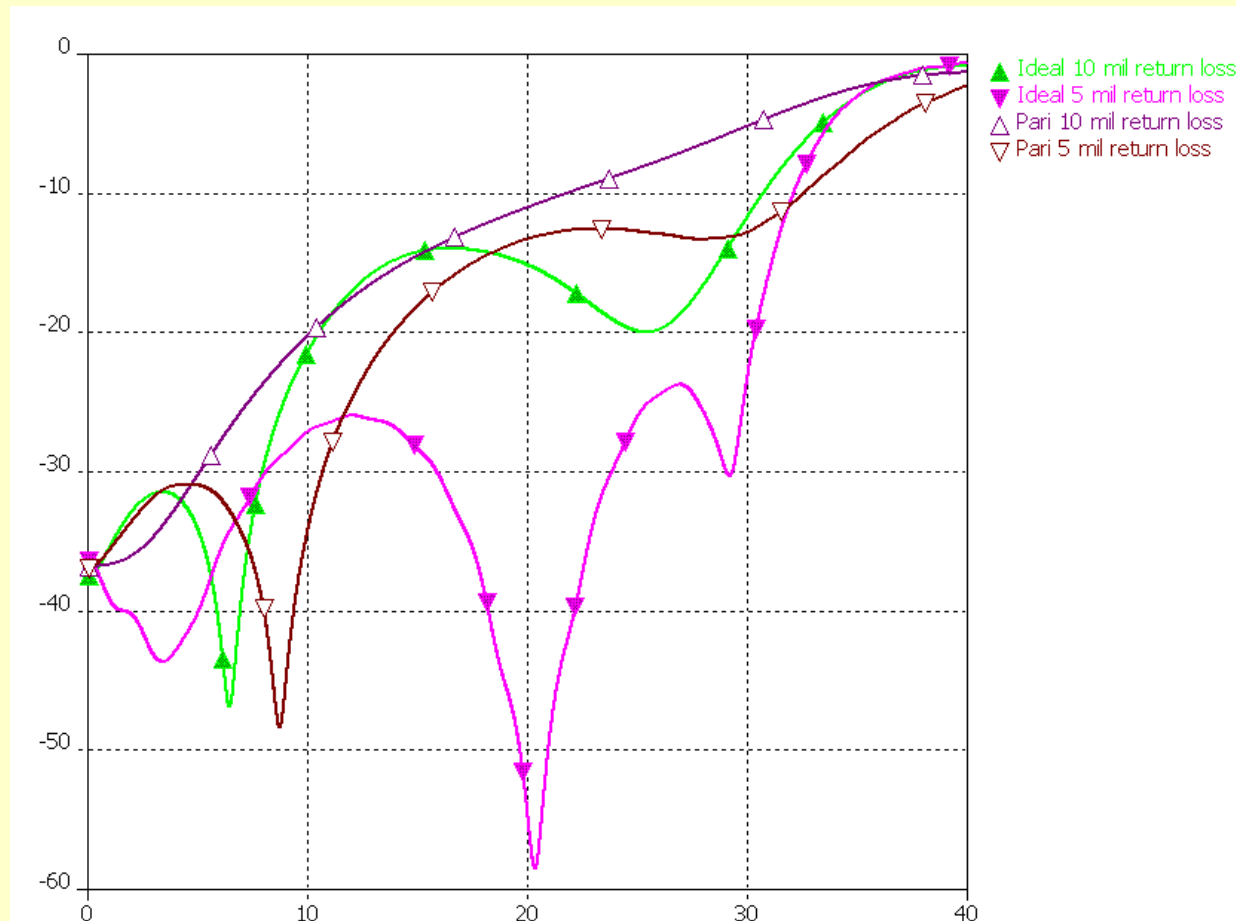

Measured Insertion Loss (SMAs, GigaCon Connector and PCB)



- PCB = 6.6" FR-4
- Flex 1 = 1" length
- Flex 2 = 2" length
- Flex 3 = 5" length

- Board to board interface without flex shows nearly identical performance to Reference test trace.
- Clearly insertion loss is well-behaved out beyond 30 GHz.

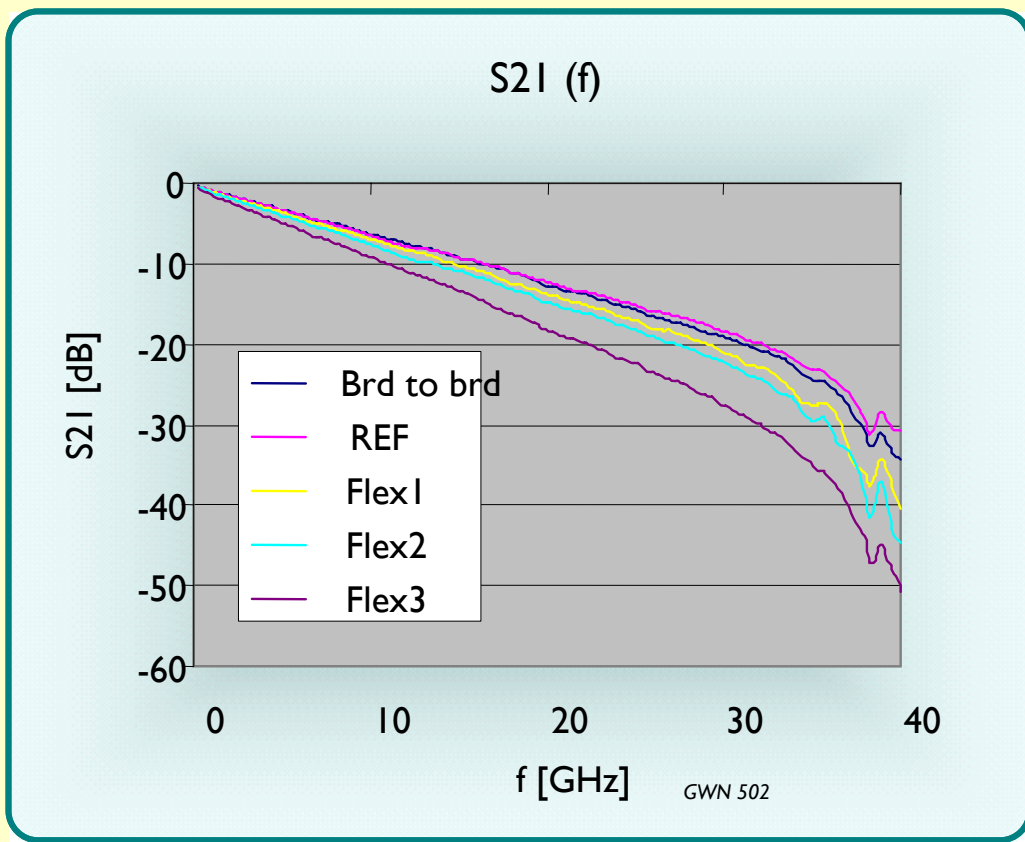

De-embedded Insertion Loss (GigaCon Connector)

- Flex 1 = 1" length
- Flex 2 = 2" length
- Flex 3 = 5" length

- Insertion loss of flex material dominates performance out to 30 GHz.

- Clearly insertion loss is well-behaved out beyond 30 GHz.

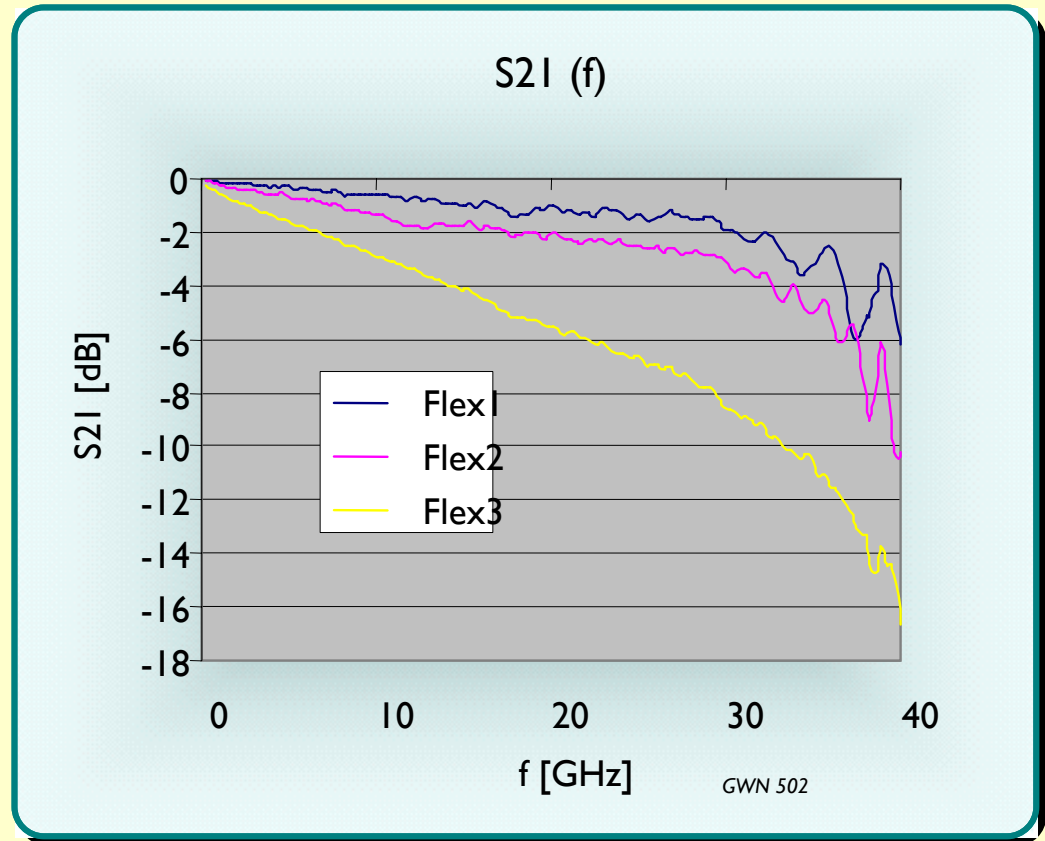

Measured Return Loss (SMAs, GigaCon Connector and PCB)



- Flex 1 = 1" length
- Flex 2 = 2" length
- Flex 3 = 5" length

- Return loss in all cases is below -12 dB beyond 30 GHz for all cases.
- Return loss appears to be limited by return loss of trace and SMA instrumentation connectors.

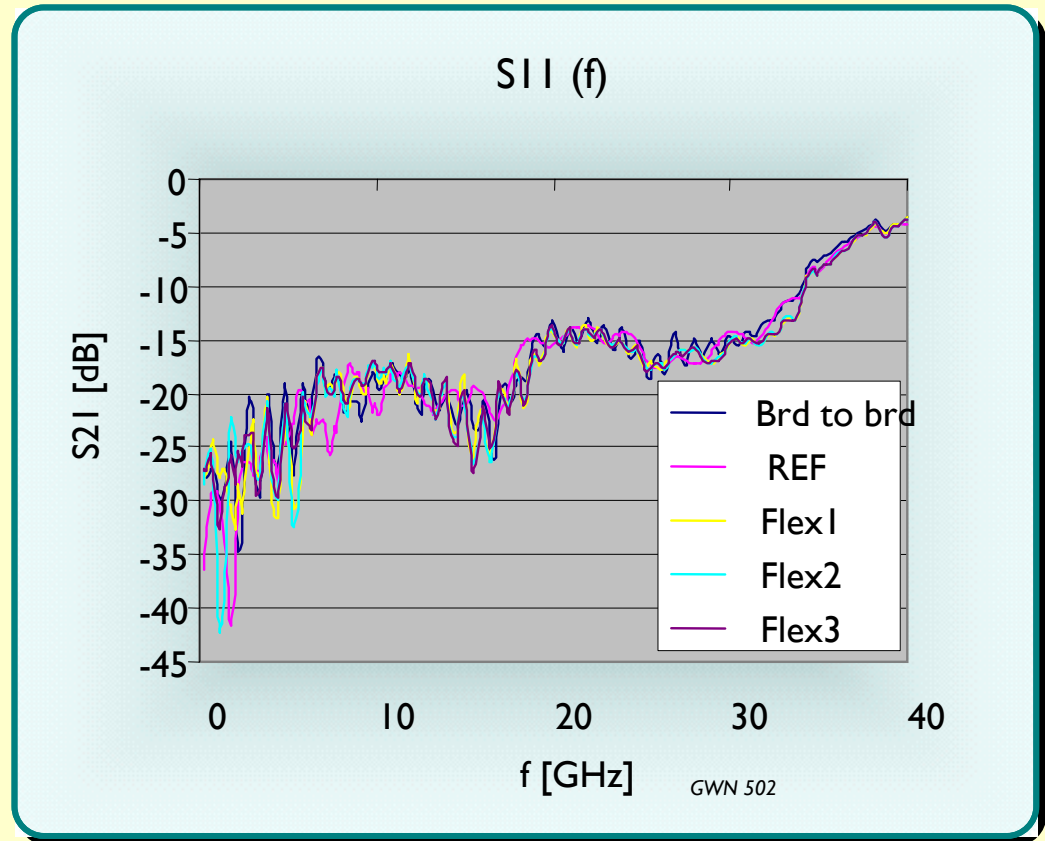

Return Loss Comparison to Modeling

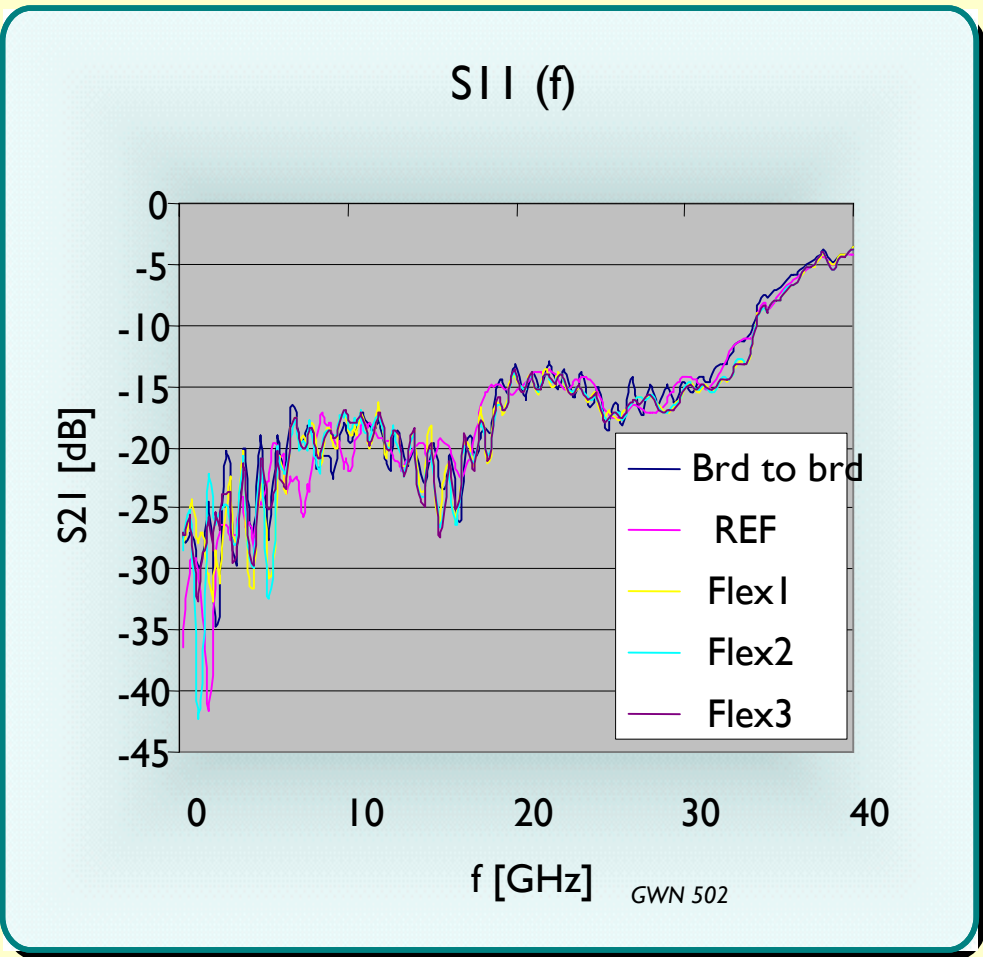
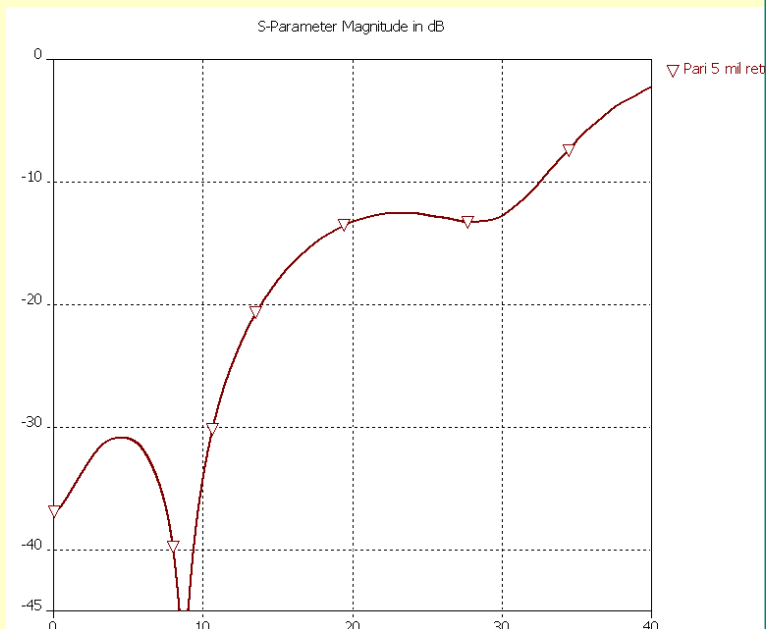

Favorable comparison with 5 mil approximate modeling.

- Simulation models created for performance study with:
 - CST Microwave Studio (connector transitions)
 - Ansoft 2D (trace cross-sections)
 - Sigriety Broadband Spice (Laplace pole/zero modeler)
- Models were converted to S-parameters with 40 GHz bandwidth, correlated to measured VNA data, and converted to HSPICE pole-zero models with Sigriety Broadband Spice.
- Eye pattern predictions were simulated in HSPICE.

GigaCon 12.5 Gbps Eyes

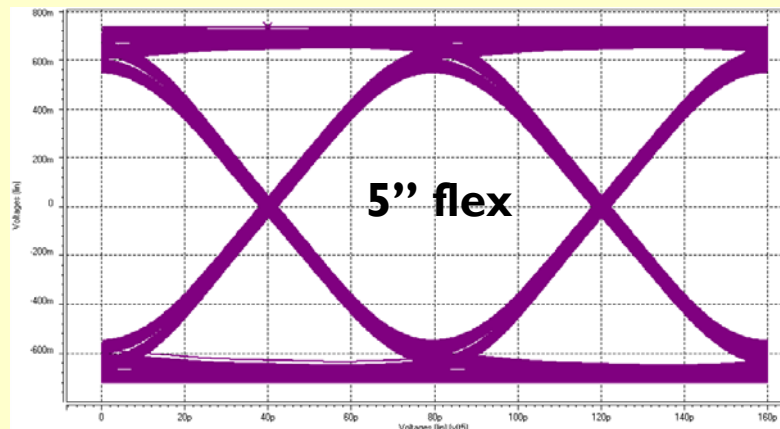
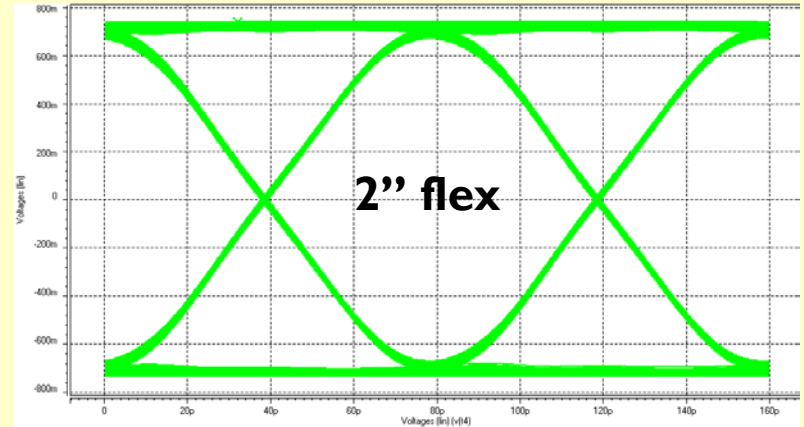
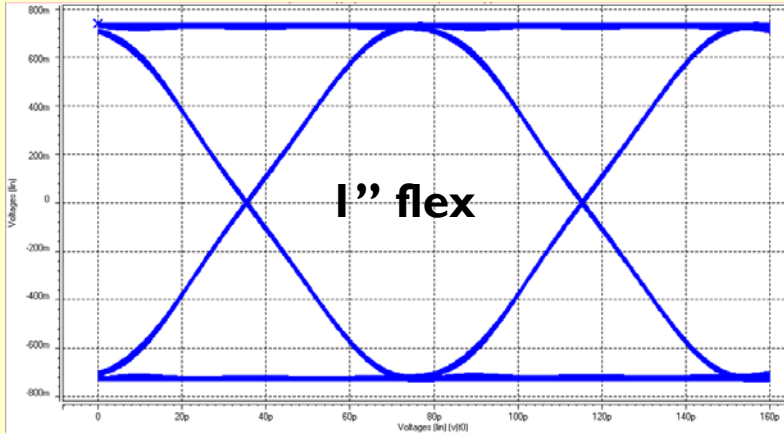

GigaCon is effectively transparent.



GigaCon 20 Gbps Eyes

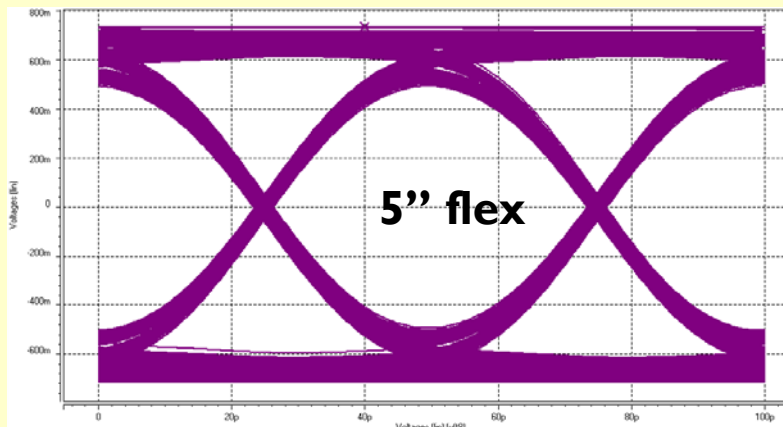
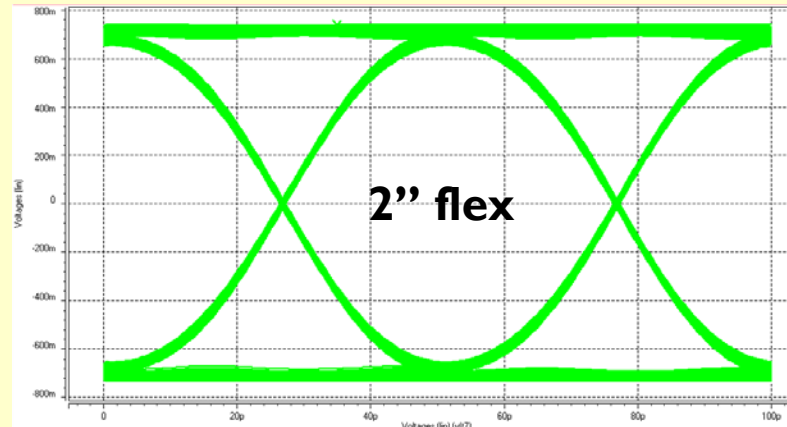
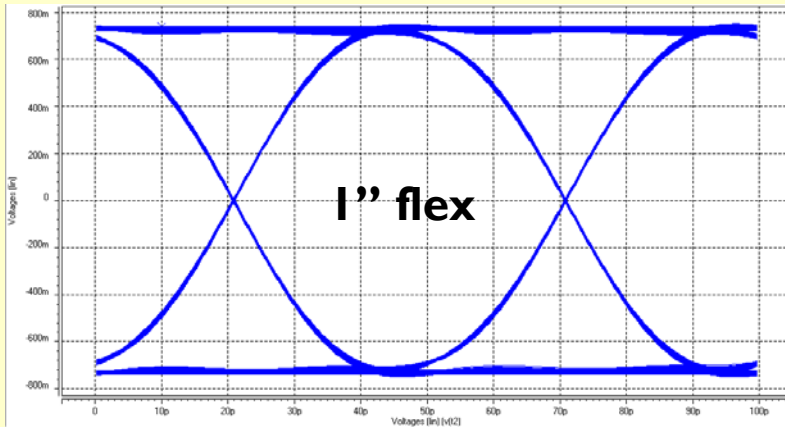

GigaCon is effectively transparent.

GigaCon 40 Gbps Eyes

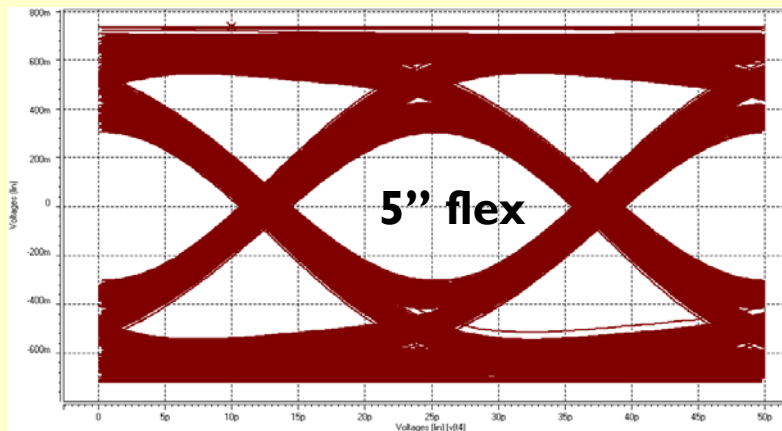
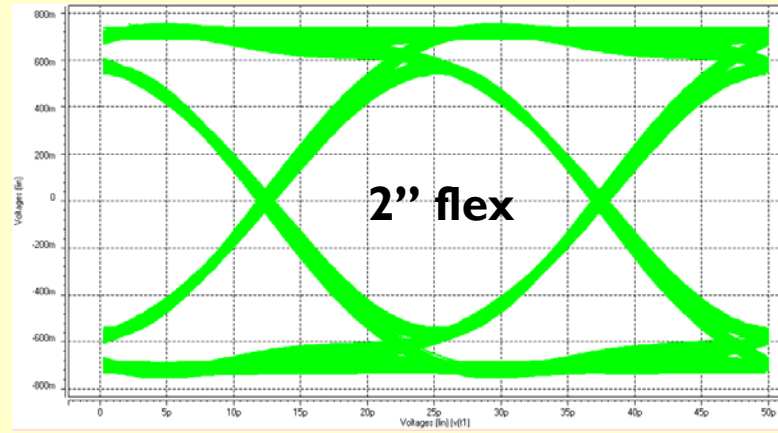
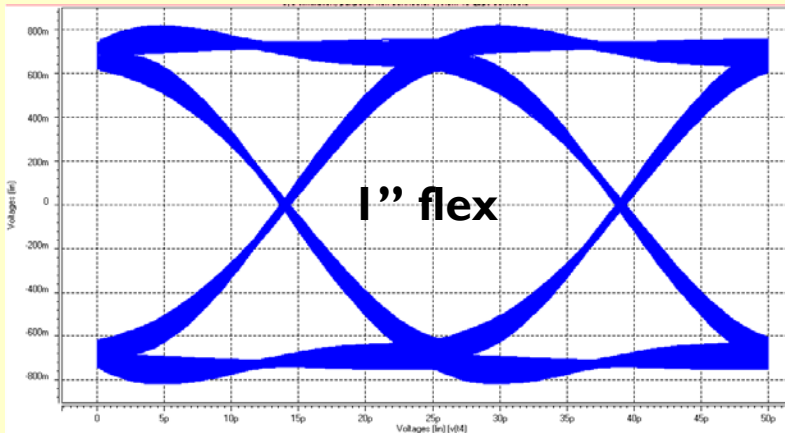

Un-equalized 40 Gbps open eyes.

GigaCon 50 Gbps Eyes

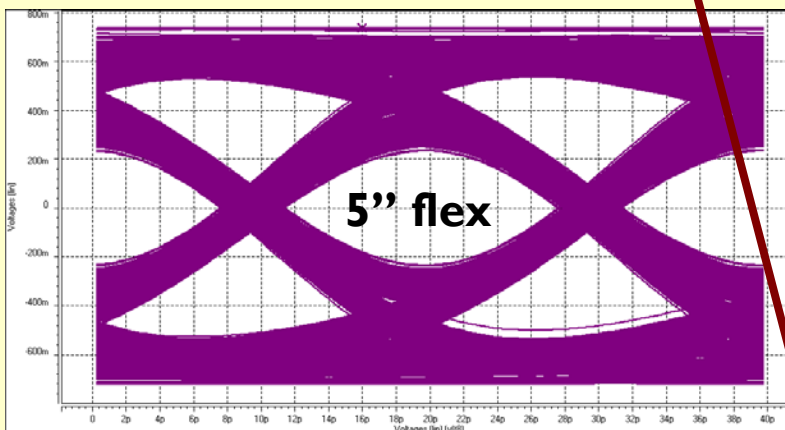
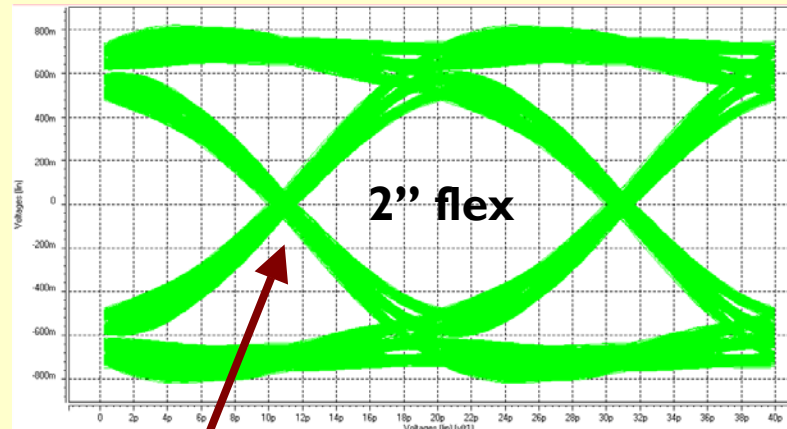
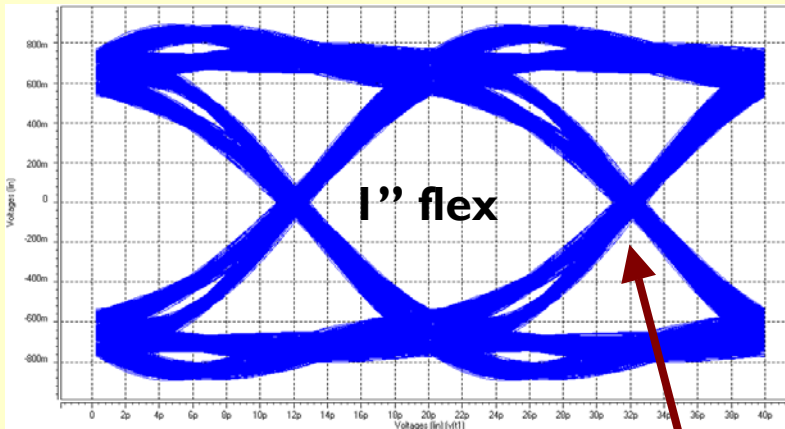

2 ps Deterministic Jitter @ 50 Gbps !



- The GigaCon connector has a demonstrated performance to 50 Gbps.
 - Connector performance is attributable to:
 - Low loss Pariposer material properties
 - The use of advanced full wave optimization.
 - Essentially transparent interconnect to 40 Gbps.
 - Easily reconfigured.
 - With bandwidth headroom for all current and foreseeable future applications.